

# JUKE

---

A simple shelf series that can be flexibly "partitioned" or "enclosed" by combining units.



2020  
GOOD DESIGN  
AWARD



## DETAILS

The simple structure of the slim frame and shelves harmonizes with various spaces.

The slim frames and shelves are designed to seamlessly blend into any interior. With a various shelf colors and the flexibility to combine multiple units, the layout can be easily customized.



Single type

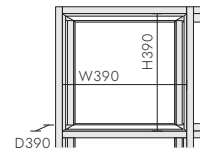
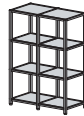

Double type

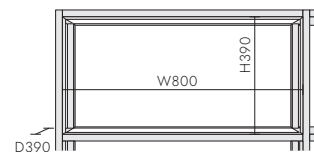

Triple type

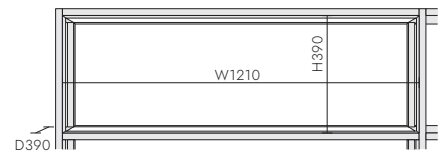
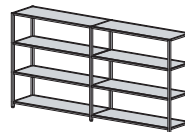

## OPTION



**Inset panel**

Inset panel to give expression to the shelf, and can also be set on the sides and back to create a box storage. A new perforated punched hole type is now also available.



**Planter shelf**

Shelves with planter boxes for placing artificial plants. Creates a comfortable space with greenery decorations.



**Gate**

Optional parts to connect shelves to each other to create a passage way to walk through. Depending on the configuration, the gate can be used to divide and enclose spaces.



**Hanging whiteboard**

Ideal for supporting planning ideas. Compact whiteboards can be used by attaching them to the frame.

# A. PRESET

The preset shelf variations are designed for straight layouts. Various sizes (width, height, depth) are available.

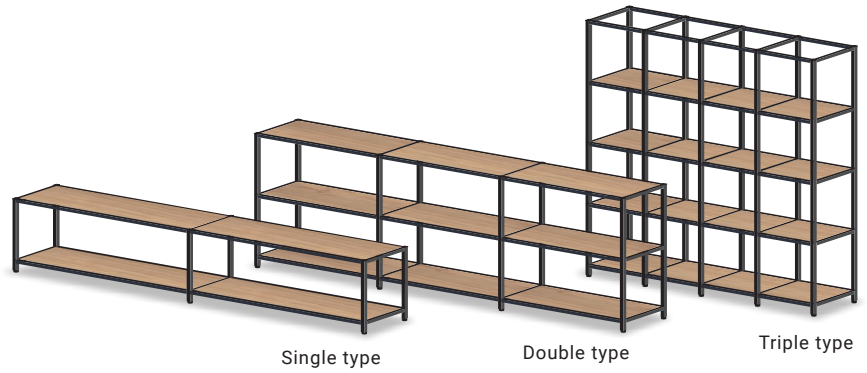

## LINEUP

Single type	1-high H490	2-high H900	3-high H1310	4-high H1720	5-high H2130
2-columns W842 X D432					
3-columns W1255 X D432					
4-columns W1665 X D432					
Double type	1-high H490	2-high H900	3-high H1310	4-high H1720	5-high H2130
2-columns W1665 X D432					
3-columns W2485 X D432					
Triple type	1-high H490	2-high H900	3-high H1310	4-high H1720	5-high H2130
2-columns W2485 X D432					
3-columns W3715 X D432					



## B. FREE COMBINATION

Various layouts can be created according to preferences. Completed by combining the shelf units and connecting components.

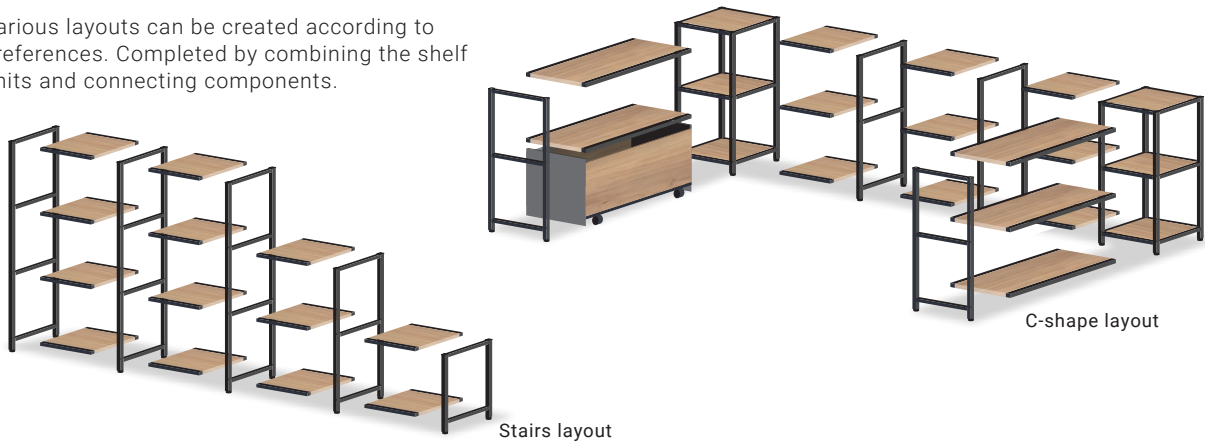

## COMPONENTS

### Shelf unit

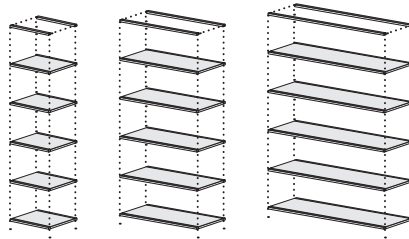

### Function unit



#### Monitor display unit

Unit to attach large monitor screens, as well as videoconferencing system equipment and speakers. Designed with cable management to neatly house wiring.

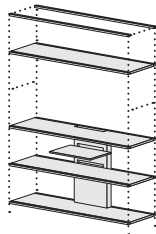

#### Wardrobe unit

Unit to hang jackets and coats. The hanging bar can be adjusted to two positions: in the middle or near front.

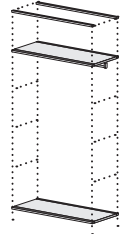

#### Drawer unit

Designed to blend in with the shelf, it can be pulled out from either side. It is also suitable for stocking supplies and storing emergency items.

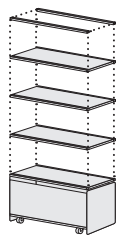

#### White board storage unit

This unit allows hanging whiteboards to be stored together when not in use. It provides easy access for quick retrieval, supporting seamless mode switching.

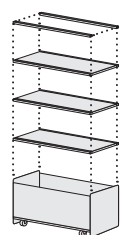

# B. FREE COMBINATION

## LINEUP

Shelf unit		1-high H490	2-high H900	3-high H1310	4-high H1720	5-high H2130
Shelf unit D430	Single type W390					
	Double type W800					
	Triple type W1210					
Drawer unit D430	Single type W390	—				
	Double type W800	—				
Monitor display unit D430 Compatible monitors Within 50inch (W1200xD380xH790)	Triple type W1210					
Wardrobe unit D430	Double type W800	—	—	—		
Whiteboard storage unit D430	Double type W800	—	—	—		
Connecting components						
Frame						
Post		—				

● Total width (when connected)=(Frame pitch × Column) + 25mm

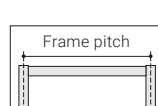

Frame pitch/  
Single · Post : 410mm  
Double : 820mm  
Triple : 1230mm

Example-1  
Double,  
5 columns

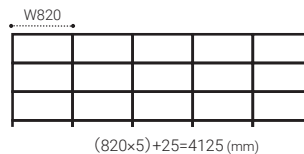

Example-2  
Single, 3-columns +  
Double, 2-columns

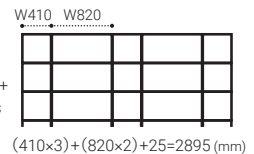

# B. FREE COMBINATION

## PLAN IMAGE

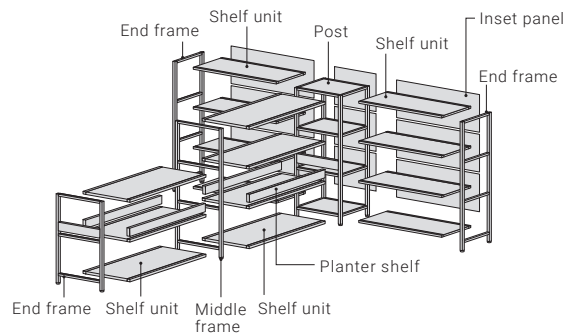
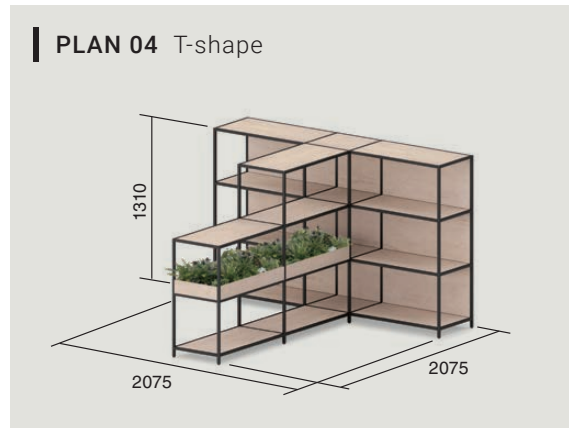
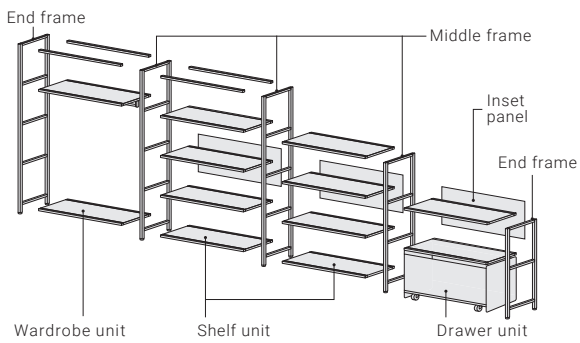
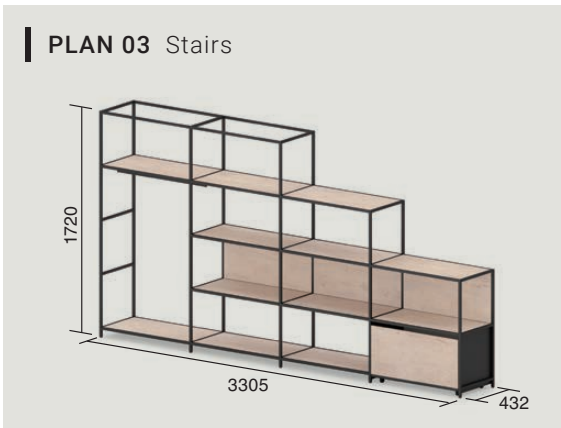
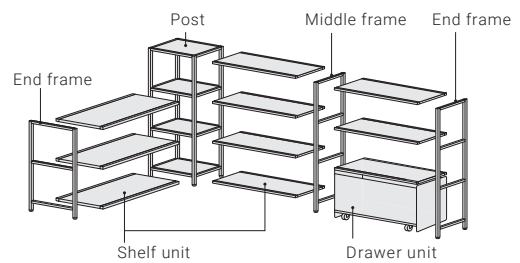
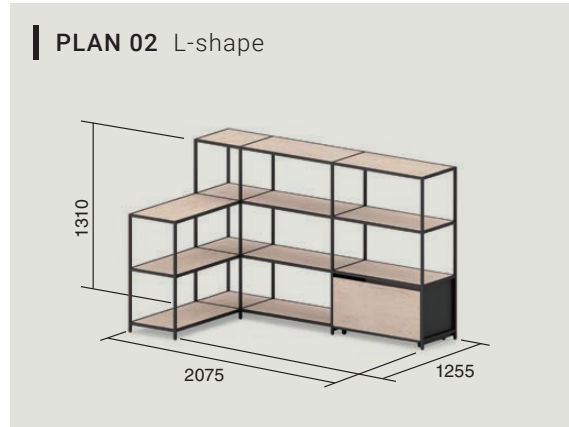
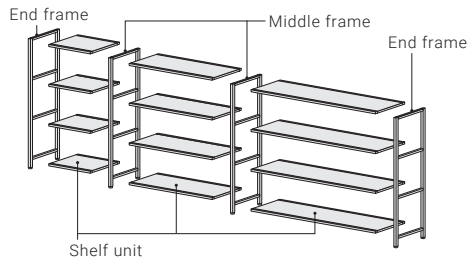
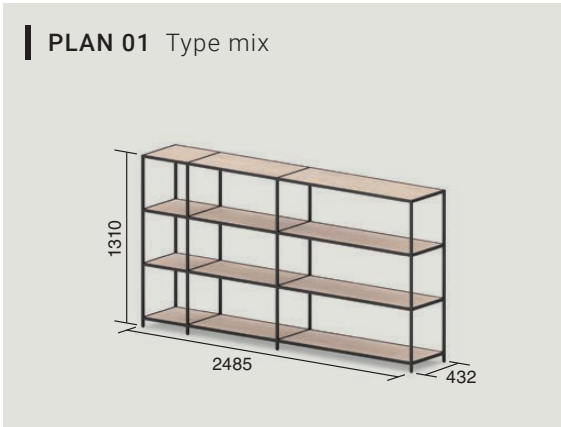

# COLOR & MATERIAL

## WHITE

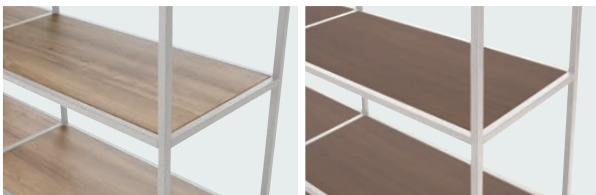
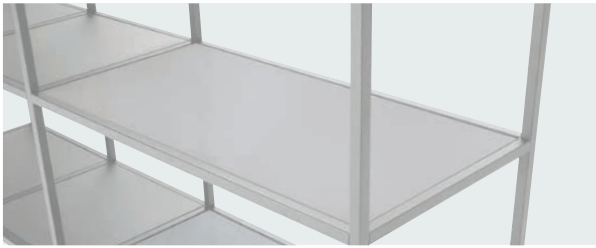

## BLACK



### Frame / Steel shelf



E1A  
White gray



E6A  
Black

### Wood grain



MW1  
Weathered natural



MP1  
Natural oak



MY3  
Timber medium



MU5  
Brown walnut

### Custom order

Antibacterial and antiviral wood grain shelves and inset panels (wood grain)



XA1



XA5

## OTHERS

### A. PRESET

Frame : Steel pipe (□19mm, Powder coated)  
 Shelf : <Steel> Steel (Powder coated)  
 <Wood grain> MFC  
 Adjusters : Nylon (Adjustable range 0-25mm)  
 \*Shelf height cannot be adjusted  
 Shelf load capacity (Even distribution)  
 Triple : 294N (Approx. 30kgf), Double : 294N (Approx. 30kgf), Single : 147N (Approx. 15kgf)

### B. FREE COMBINATION

#### <Common to shelf units>

Frame : Steel pipe (□19mm, Powder coated)  
 Shelf : <Steel> Steel (Powder coated)  
 <Wood grain> MFC  
 Adjusters : Nylon (Adjustable range 0-25mm) \*Shelf height cannot be adjusted  
 Shelf load capacity (Even distribution)  
 Triple : 294N (Approx. 30kgf), Double : 294N (Approx. 30kgf), Single : 147N (Approx. 15kgf)

#### <Monitor display unit>

●Includes one middle shelf  
 Middle shelf load capacity: 98N (Approx. 10kgf)

#### <Wardrobe unit>

●Includes one hanger pipe  
 Hanger pipe load capacity: 196N (Approx. 20kgf)

#### <Drawer unit / Whiteboard storage unit>

Castors : Straight castor  
 Drawer load capacity (Even distribution) :  
 <Double> 294N (Approx. 30kgf), <Single> 147N (Approx. 15kgf)